

4B-W  
Health Care Oxygen Concentrator  
Operation Instructions



# ***CONTENT***

<b>INTRODUCTION</b> .....	<b>1</b>
<b>HIGHLIGHTS</b> .....	<b>1</b>
<b>PRINCIPLE OF WORKING</b> .....	<b>1</b>
<b>APPLIED RANGE</b> .....	<b>2</b>
<b>SPECIFICATIONS</b> .....	<b>3</b>
<b>OPERATION INSTRUCTIONS</b> .....	<b>3</b>
<b>WORKING ENVIRONMENT</b> .....	<b>6</b>
<b>CIRCUIT PRINCIPLE PICTURE</b> .....	<b>6</b>
<b>REGULAR MAINTENANCE</b> .....	<b>7</b>
<b>CAUTIONS</b> .....	<b>8</b>

## **INTRODUCTION**

The oxygen concentrator is based on the Pressure Swing Adsorption (PSA) Technology derived technology that utilizes unique molecular sieves to separate air into its constituent parts of Nitrogen, Oxygen and trace gases. The oxygen concentrator redirects the oxygen for use out the front, while it ejects the nitrogen and trace gases back into the atmosphere. The PSA system was developed as an alternative to the cryogenic separation of gases whose purity of oxygen accords with medical standard.

Atomizing device can be fitted if necessary, oxygen therapy and atomizing therapy being implemented simultaneously.

## **HIGHLIGHTS**

No other raw material are needed except air; low consumption of power and low cost of oxygen production, All gas circuit is controlled by low pressure system, which operates securely and reliably, Adjustable flow rate; making oxygen while supply continuously, switch on or off at any time convenient operation; excellent performance; low noise Atomizing device can be fitted if necessary, oxygen therapy and atomizing therapy being implemented simultaneously.

## **PRINCIPLE OF WORKING**

For 4B-W oxygen concentrator working principle please see Fig1.

The magnetic valve is controlled by Power Control Board (CPU). When the magnetic valve is in position 1, the air compressed by oil-free air-compressor enters the molecular sieve bed A through the opening valve entrance P to A. The nitrogen adsorbed, and the oxygen in the molecular sieves bed A entering oxygen storing tank through one-way valve. Then the oxygen comes from pressure regulating valve and flow meter into humidifier to get wet. Thus it can be available for people. Less oxygen will come to bed B through washing

hose exhausted to the air together with the desorbed nitrogen from the opening valve entrance B to S. When the magnetic valve is in position 2, the compressed air comes into molecular sieve bed B through the opening valve entrance P to B, oxygen coming into the tank through one way valve for people to take. Less oxygen return to the molecular sieves bed A through the washing hose exhausted to the air together with the desorbed nitrogen from the opening valve entrance A to S. It will start a new cycle after the working cycle end. In this way, the oxygen is supplied to oxygen storage tank by the two molecular sieves in turn, which can produce the oxygen directly from the air.

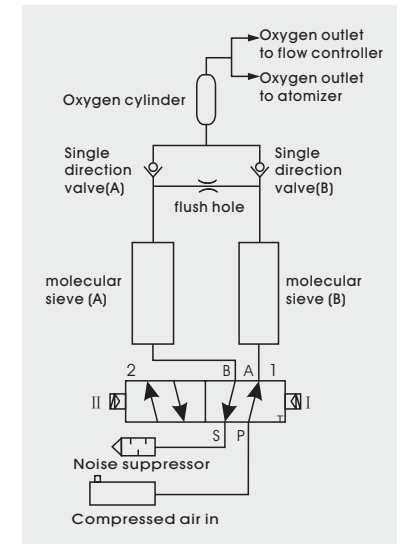

Fig1

## **APPLIED RANGE**

The oxygen concentrator is widely used at home or in hospital, clinics, health care centers, rest homes, P.E training centers, body-building centers, high mountains, beauty salons and oxygen bars.

It is also used for oxygen treatment such as Respiratory Diseases, Cardiovascular Diseases, Cerebrovascular Accidents, plateau Diseases and oxygen care (the middle-aged or aged, brain fatigue, athletic fatigue and air conditions disease.) so on.

## **SPECIFICATIONS**

Voltage: 230V 10% 50Hz  
Power consumption: 450W  
Oxygen concentration: 93% 3%  
Oxygen flow: 0 ~ 4L/min  
Oxygen delivery pressure: 0.03 ~ 0.07MPa  
Noise: ≤50dB(A)  
Overall size: 480(L) 500(W) 750(H)(mm)  
Net weight: 28.5Kg  
Electric classification: Class II Grade B  
Alarm: power failure, high pressure, low pressure

## **OPERATION INSTRUCTIONS**

### **1. Name of parts and its function**

Flow controller — it can adjust the oxygen flow and display the flow value through the adjusted knob.

Power switch — when it is connected to the switch with power on, the oxygen concentrator will start to work; when it is connected to the switch with power off, the oxygen concentrator can not work and occur alarming at the same time.

Atomize outlet — it connects the drug atomizer.

Power indicator(green) — the power indicator will be green when power on. When power is cut off, the power indicator will turn off and the oxygen concentrator will alarm at the same time.

Atomize knob — when the drug atomizer connects to the atomizing outlet, turn on the atomizing knob, it will atomize therapy at once. For 4L and 5L, oxygen can

be supplied while atomizing is proceeded.

But for 3L, either oxygen or atomizing can be proceeded separately.

Timer — it can record the accumulated time which oxygen concentrator has operated.

Humidifier — when the humidifier is filled with distilled water, connect the screw nut on the top of the humidifier to the oxygen outlet under the flow controller of the oxygen concentrator. The oxygen will be moistened by the humidifier, it will flow out of outlet of the upper-cover. Nasal cannula should

attach to the humidifier outlet port. There is a safety valve on the humidifier cover, whose pressure is 0.02 0.005MPa.

Intake Filter net — it can keep the dust and dirt from being absorbed into the oxygen concentrator. It should be cleaned once every other week.

Inlet filter — air two filtrations.

Power socket fuse box — the power cord is connected to the oxygen concentrator by the socket. one 5A fuse and its spare part have been installed in the box when the product is finished. You can change the fuse, when opening the cover with the screw driver.

Exhaust window — it can exhaust the nitrogen and ventilate the heat, which should be with no other obstruction.

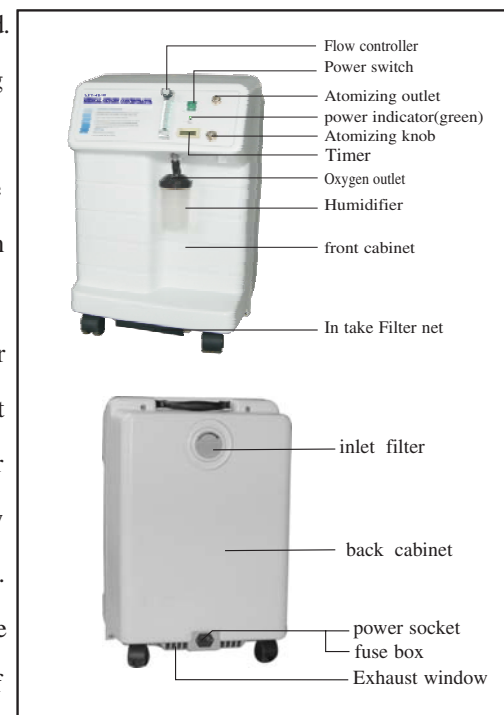

## Atomizing methods

(Applied in the oxygen concentrator with atomizer)

The oxygen concentrator starts to work.

Pour the medicine solution into atomizing cup, tighten it clockwise.  
Attach tube to the atomizer outlet, turn off oxygen flow

on the atomizing knob. Put the Atomize nozzle into the mouth with hand for treatment.

Please close the atomizing knob after finishing the drug atomizer. If you do not continue to absorb oxygen, you can turn off the machine.

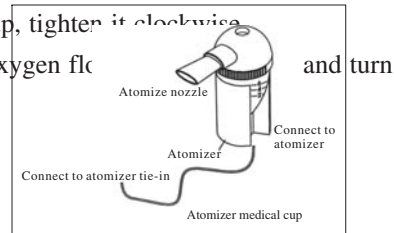

## 2. The method of inhaling oxygen

Please take the oxygen concentrator out of the carton and Plug one end of the power cord with holes into the socket of oxygen concentrator, connecting the other end to 110V power. Power indicator will turn green.

Unscrew the cover of humidifier, and fill distilled water or cold boiled water to the humidifier in the level between Max and Min and screw the cover of humidifier tightly. Then screw the nut on the top of humidifier tightly to the oxygen outlet of oxygen concentrator.

Attach oxygen nasal cannula to the humidifier outlet port.

Press the power switch button, the green light indicates the oxygen concentrator is working.

The flow controller can be adjusted by the switch on the flowmeter, turn the switch around until the ball in the flowmeter is located where is needed.

Put on nasal oxygen cannula as the picture shows.

When you finish absorbing the oxygen, you should turn off the oxygen concentrator, and take the nasal

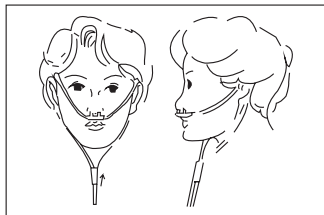

oxygen cannula out of the humidifier, and turn off the flow controller at the same time.

## WORKING ENVIRONMENT

Temperature: 0°C ~ 40°C, relative humidity: ≤ 80%

Air pressure: 86Kpa ~ 106Kpa

Working power: 230V 10% 50Hz

## CIRCUIT PRINCIPLE PICTURE

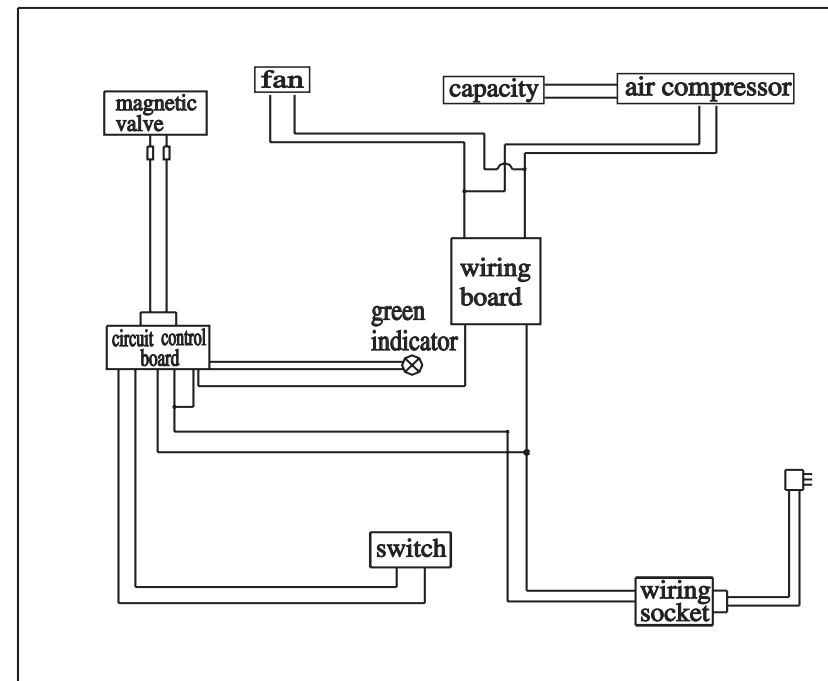

## REGULAR MAINTENANCE

Item	Faults	Possible cause	Remedy
1	When switch on or insert ICard, doesn't work, indicator doesn't give light or alarm can be heard	<ol style="list-style-type: none"> <li>1. Power doesn't put through</li> <li>2. Socket is with no</li> <li>3. Fuse failed installed or damaged</li> </ol>	<ol style="list-style-type: none"> <li>1. Check if power cord is Ok</li> <li>2. Check if the power is on</li> <li>3. Open power socket to check if power use or change it</li> </ol>
2	The machine stopped working or the purity decrease after it work for some time	<ol style="list-style-type: none"> <li>1. Intake or exhaust window are blocked</li> <li>2. Intake net get dirty</li> <li>3. Intake filter get dirty</li> <li>4. Ambient temperature is over high</li> <li>5. Voltage is over low</li> <li>6. Fan doesn't work</li> </ol>	<ol style="list-style-type: none"> <li>1. Check the intake and exhaust window.</li> <li>2. Clean the intake net</li> <li>3. Open maintenance window and loose the intake filter for cleaning or change</li> <li>4. Put the machine where is airy</li> <li>5. Guarantee the voltage of 230V</li> <li>6. Change Fan</li> </ol>
3	No oxygen is sent out after the machine operates or no bubbles come out from humidifier	<ol style="list-style-type: none"> <li>1. The flow controller doesn't turn on (ball doesn't rise)</li> <li>2. The nasal cannula folded</li> <li>3. Trouble caused by the machine itself</li> </ol>	<ol style="list-style-type: none"> <li>1. Turn on the flow controller to see if the ball inside rise up</li> <li>2. Make sure the nasal cannula is well through</li> <li>3. Contact us</li> </ol>
4	Loud noise can be heard while the machine operates	Trouble caused by the machine itself	Contact us
5	High or low alarm will be heard while the machine working	Trouble caused by the machine itself	Contact us

## CAUTIONS

- Read this instruction carefully before use
- Do not use near open flames and no smoking
- Do not turn on or turn off the machine too frequently. 5-minute break is acceptable to prevent the compressor from starting with the pressure or shortening its life. Turn off the flow controller while turning off the machine.
- Keep the intake and exhaust window through to prevent the machine from getting too heated and failing to work.
- Change the water in the humidifier frequently (twice a week), clear the water in case of no use for a long time.
- Sterilize the oxygen cannula with alcohol before use.
- Clean the intake net frequently (once a month) and dry it before reuse.
- Open the maintenance window every three months and take the intake filter out for clean or change it when purity decrease. Normally, the intake filter should be changed one a year.
- Clean the machine with power off